

Installation and Maintenance Instructions Freewheel Type ASNU

To avoid premature failure of the freewheel or possible machine malfunction, installation of the freewheel should be carried out by suitably qualified personnel and according to the following instructions.

STIEBER will not accept liability in cases of non-compliance with these instructions!

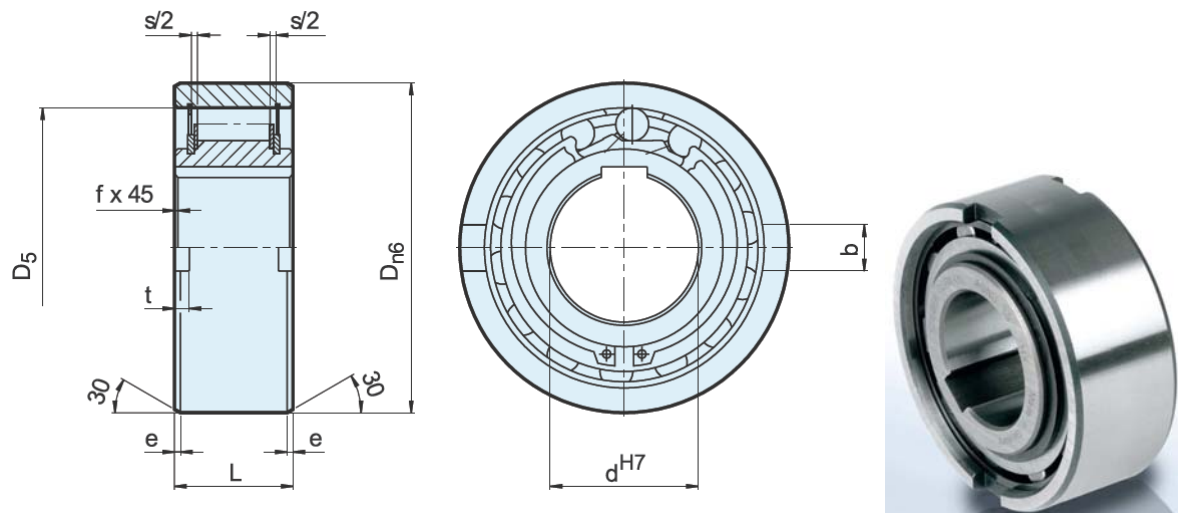

Type	Size	Overrunning Speeds										Weight	Drag torque	
		$T_{KR}^{(1)}$ [Nm]	$n_{max}^{(2)}$ [min ⁻¹]	$n_{amax}^{(3)}$ [min ⁻¹]	D_{sk} [mm]	L [mm]	D_5 [mm]	b [mm]	t [mm]	s [mm]	e [mm]			f [mm]
ASNU	8	12	3300	5000	35	13	28	4	1.4	2.4	0.6	0.3	0.07	1.6
	12	12	3300	5000	35	13	28	4	1.4	2.4	0.6	0.3	0.06	1.6
	15	30	2400	3600	42	18	37	5	1.8	2.4	0.8	0.3	0.11	1.9
	17	49	2300	3400	47	19	40	5	2.3	2.4	1.2	0.8	0.15	1.9
	20	78	2100	3100	52	21	42	6	2.3	2.4	1.2	0.8	0.19	1.9
	25	125	1700	2600	62	24	51	8	2.8	2.4	1.2	0.8	0.38	5.6
	30	255	1400	2200	72	27	60	10	2.5	2.4	1.8	1	0.54	14
	35	383	1200	1900	80	31	70	12	3.5	2.4	1.8	1	0.74	16
	40	538	1100	1700	90	33	78	12	4.1	2.5	1.8	1	0.92	38
	45	780	1000	1600	100	36	85	14	4.6	2.5	1.8	1	1.31	43
	50	1013	850	1350	110	40	92	14	5.6	2.5	1.8	1	1.74	55
	60	1825	750	1050	130	46	110	18	5.5	3.6	2.6	1.5	2.77	110
	70	2300	600	950	150	51	125	20	6.9	3.6	2.6	1.5	4.16	140
	80	3275	550	850	170	58	140	20	7.5	3.6	2.6	1.5	6.09	180
	90	5325	500	750	190	64	160	20	8.0	3.6	2.6	2	8.2	230
	100	7250	450	680	215	73	175	24	8.5	3.6	2.6	2	12.6	380
	120	13500	370	550	260	86	215	28	10	3.6	2.6	2.5	22	650
150	26625	300	460	320	108	260	32	12	3.6	3.6	2.5	42	1000	
200	44500	230	350	420	138	350	45	16	7.6	3.6	3	93	2000	

Prior to Installation:

The freewheels should be unpacked and installed in a clean dry working environment.

Remove the corrosion inhibitor using flushing oil. The freewheeling direction should be checked prior to installation. (Reverse unit on shaft to change freewheeling direction.)

The inner race should be fitted to a shaft of h6 or j6 tolerance.

The outer housing should be to H7 or K6 tolerance.

The concentricity and angular alignment of the shaft relative to the outer housing should be within the limits specified in the table below.

Permissible run-out and squareness errors:

Bore Ø [mm]	Run-out TIR [mm]	Squareness TIR [mm]	Axial Clearance S [mm]
8-15	0,02	0,03	2,4
17-35	0,035	0,03	2,4
40-50	0,06	0,03	2,5
60-100	0,1	0,045	2,5
110-150	0,16	0,045	3,6
200	0,2	0,06	7,6

We recommend ball bearings with normal bearing clearance are installed adjacent to the freewheel.

Installation:

Use a key to DIN 6885 sheet 1, for sizes 8 and 12. To DIN 6885 sheet 3, for other sizes.

The key should be the length of the freewheel hub. Torque is transmitted at the outer race via a pressfit (K6/n6), or by the slots in the outer race. (The housing can be to H7 tolerance if the slots are used to transmit torque)

During installation, an evenly distributed axial load should be applied simultaneously to both the inner and outer races.

Avoid localised axial loading on either the inner or outer race.

After Installation:

After installation, ensure the unit rotates smoothly in the direction of freewheeling.

Prior to use, 1/3 to 1/2 of the free space within the unit should be filled with oil of the recommended grade.

Lubrication and Maintenance:

- The lubricating oil should be changed after approximately 10 hours operation. Further oil changes should be made after every 2000 hours. (In arduous applications change oil every 1000 operating hours).
- With ambient temperatures above 80°C, check lubrication regularly.

- For operating temperatures below -20°C and above 100°C contact the technical department of your lubricant suppliers.
- For indexing applications, oil types with a kinematic viscosity of about 10mm²/s at the normal operating temperature are recommended.
- If grease lubrication is to be used please consult your STIEBER stockist. Excessive grease may lead to malfunction of the freewheel. Only 30 to 40% of the free space between the races should be grease filled.

Lubricants with slip additives such as graphite, Molykote or similar agents should be avoided

Recommended Lubricants

	Ambient temperature				Grease
	-40°C to- 15°C	-15°C to +15°C	+15°C to +30°C	+30°C to +50°C	
	Operating temperature				
	-20°C to +20°C	+10°C to +50°C	+40°C to +70°C	+50°C to +85°C	
	Oil				
ISO - VG DIN 51519	10	22	46	100	
ARAL	SUMOROL CM10	SUMOROL CM22	MOTANOL HK46	DEGOL CL100T	ARALUB HL2
BP	ENERGOL CS10	ENERGOL CS22	ENERGOL CS46	ENERGOL RC100	ENERGREASE LS2
DEA	ASTRON HL10	ASTRON HL22	ASTRON HL46	ASTRON HL100	GLISSANDO 20
ESSO	NUTO H10 SPINESSO 10	NUTO H22 SPINESSO 22	NUTO H46 TERESSO 46	NUTO H100	BEACON 2
FUCHS	RENOLIN MR3	RENOLIN DTA22	RENOLIN DTA46	RENOLIN MR30	RENOLIT LZR2
KLÜBER	CRUCOLAN 10	CRUCOLAN 22	CRUCOLAN 46	CRUCOLAN 100	POLYLUB WH2
MOBIL	VELOCITE No6	VELOCITE No10	VACTRA MEDIUM VG46	VACTRA HEAVY VG100	MOBILUX 2
SHELL	MORLINA 10	MORLINA 22	MORLINA 46	MORLINA 100	ALVANIA G2
TOTAL	AZZOLA ZS10	AZZOLA ZS22	AZZOLA ZS46	AZZOLA ZS100	MULTIS 2

Alternatively we strongly recommend the use of multigrade oils SAE 10W-40 at working temperature between 0° and +80 ° C.

The ambient temperature is to be taken as a guide line. The operating temperature is determinant for the choice of the viscosity.

Corrosion inhibitor: Rivolta KSP

Time of protection: 6 to 12 months

Recommendation: Prior to use, remove corrosion inhibitor using flushing oil.

The maximum overrunning speeds given in our literature apply to oil lubricated units. For grease lubrication the quoted speeds must be halved. Please refer to the 'Lubrication & Maintenance' section in our main catalogue.