

RSCI 20-130



TYPE



Type RSCI is a centrifugal lift off sprag type freewheel with the inner race rotating. Only the inner race is designed for freewheeling. It is a non self-supported type.

Bearings must be provided to ensure concentricity of the inner and outer races and support axial and radial loads, as shown overleaf. Concentricity and run-out limits must be observed. The RSCI type accepts all types of lubricant currently used in power transmission equipment.

It is possible to mount these freewheels directly in gear-boxes without separate lubrication. An oil mist is generally sufficient. Grease lubrication may be acceptable if the unit works mostly in overrunning condition, as on E-motors.

When used as a backstop, it must be checked that the overrunning speed will not go below the minimum speed given in the characteristics table. Please refer to page 78 (RSCI 180-300) for further information.

RSCI

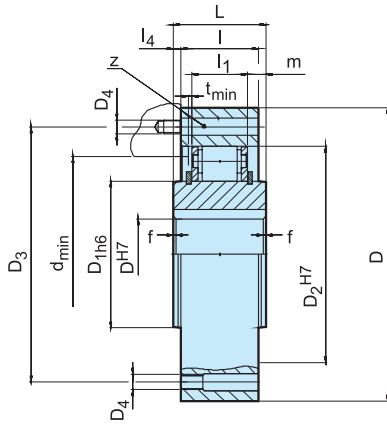

F8

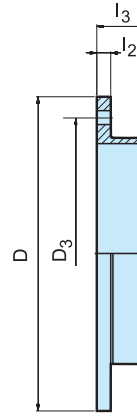

Type	Size	Speeds															Number					Weight	
		$T_{KN}^{1)}$ [Nm]	$n_{max}^{2)}$ [min ⁻¹]	$n_{min}^{3)}$ [min ⁻¹]	$n_{imax}^{4)}$ [min ⁻¹]	$D^{5)}$ [mm]	D_{1h6} [mm]	D_{2H7} [mm]	D_3 [mm]	D_4 [mm]	z	L [mm]	l [mm]	l_1 [mm]	l_4 [mm]	$f \times 45^\circ$ [mm]	d_{min} [mm]	m [mm]	t_{min} [mm]	l_2 [mm]	l_3 [mm]	RSCI [kg]	F8 [kg]
RSCI	20	212	315	750	14500	90	36	66	78	M6	6	35	35	25	0	0.8	52	5	1	8	16	1.5	0.3
	25	319	300	725	14300	95	40	70	82	M6	6	35	35	25	0	1.0	56	5	1	8	16	1.6	0.4
	30	375	290	700	11400	100	45	75	87	M6	6	35	35	25	0	1.5	62	5	1	8	16	1.8	0.4
	35	550	280	670	10500	110	50	80	96	M6	8	35	35	25	0	1.5	66	5	1	8	16	2.1	0.5
	40	800	260	630	7600	125	60	90	108	M8	8	35	35	25	0	1.5	76	5	1	10	21	2.7	0.7
	45	912	255	610	6600	130	65	95	112	M8	8	35	35	25	0	1.5	82	5	1	10	21	2.9	0.9
	50	1400	235	560	6100	150	80	110	132	M8	8	40	40	25	0	1.5	100	7.5	1	10	21	4.3	1
	60	2350	210	510	5300	175	85	125	155	M10	8	60	50	36	5	2.0	110	12	2	12	35	6.5	1.8
	70	3050	195	470	4100	190	100	140	165	M10	12	60	50	36	5	2.0	120	12	2	12	35	8.6	1.9
	80	4500	180	440	3600	210	120	160	185	M10	12	70	60	36	5	2.0	140	17	3	12	35	12.5	2.6
	80M	5800	155	375	4000	210	120	160	185	M10	12	70	60	46	5	2.0	140	12	2	12	35	13.1	2.6
	90	5600	170	410	2700	230	140	180	206	M12	12	80	70	36	5	2.5	165	22	3	12	35	17.4	3.0
	90M	8700	145	350	3000	245	140	180	206	M12	12	80	70	46	5	2.5	160	17	2	12	35	18.3	3.0
	100	10500	145	355	2700	290	140	210	258	M16	12	90	80	52.6	5	2.5	180	18.6	3	15	37	28	5.0
	100M	16000	140	340	2400	290	170	210	258	M16	12	90	80	63	5	2.5	200	13.5	2	12	35	30	5.0
130	15750	135	330	2400	322	170	240	278	M16	12	90	80	52.6	5	3.0	210	18.6	3	15	37	35	6.0	

NOTES

- $T_{max} = 2 \times T_{KN}$
» Refer to Selection page 10 to 13
- This maximum allowable torque transmission speed n_{max} must not be exceeded when transmitting torque
- This minimum allowable overrunning speed n_{imin} should not be reduced under continuous operation. Possible reduction of this minimum speed on request
- Inner race overruns
Keyway to DIN 6885.1
- Tolerance +1

Cover F8 must be ordered separately
» Refer to mounting and maintenance instructions page 16 to 19

Other bore diameters on request

MOUNTING EXAMPLE

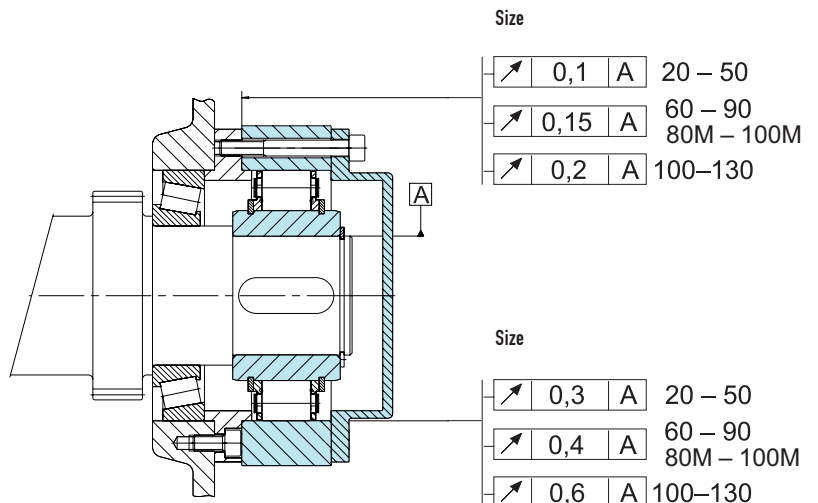

RSCI 180-300



TYPE



Type RSCI is a centrifugal lift off sprag type freewheel with the inner race rotating. Only the inner race is designed for freewheeling.

Primarily designed as a backstop, this type can be also used as an overrunning clutch in crawl drives, where the

overrunning speed is high but the driving speed is low and does not exceed the maximum driving speed shown in the table. Centering of the outer race must use the inner bore. The centering spigot must not contact the sprag cage. Please refer to page 76 (RSCI 20-130) for further information.

RSCI

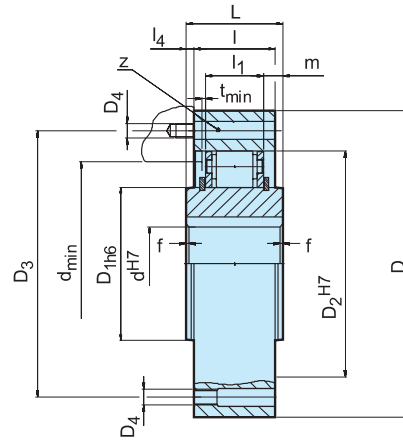

Size	Torque	Speeds			Number							Weight							
d^{H7} [mm]	$T_{KN}^{1)}$ [Nm]	$n_{max}^{2)}$ [min ⁻¹]	$n_{min}^{3)}$ [min ⁻¹]	$n_{imax}^{4)}$ [min ⁻¹]	$D^{5)}$ [mm]	D_{1h6} [mm]	D_2^{H7} [mm]	D_3 [mm]	D_4 [mm]	z	L [mm]	l [mm]	l_1 [mm]	l_4 [mm]	$f \times 45^\circ$ [mm]	d_{min} [mm]	m [mm]	t_{min} [mm]	[kg]
180	31500	115	285	1300	412	240	310	360	M20	12	90	80	53	5	3,5	280	18,6	3	59
180 M	50000	90	220	1300	422	240	310	370	M20	18	120	120	83	0	4	280	18,5	2	92
180 II	63000	115	285	1300	412	240	310	360	M20	24	160	160	118	0	3,5	280	21	3	116
180 II-M	100000	90	220	1300	425	240	310	370	M24	24	240	240	176	0	4	280	32	3	190
220	42500	110	265	1100	470	290	360	410	M20	16	105	80	60	12,5	4	330	19,5	3	90
220 M	68000	85	205	1100	480	290	360	410	M24	16	120	120	83	0	4	330	18,5	2	109
220 II	85000	110	265	1100	480	290	360	430	M24	18	160	160	130	0	4	330	15	3	159
220 II-M	136000	85	205	1100	490	290	360	425	M30	20	240	240	176	0	4	330	32	2	249
240	52000	105	250	1100	500	320	390	440	M20	16	105	90	60	7,5	4	360	15	2	95
240 M	83000	80	195	1100	520	320	390	440	M24	16	120	120	83	0	4	360	18,5	2	137
240 II	104000	105	250	1100	505	320	390	440	M24	24	180	180	132	0	4	360	24	2	191
240 II-M	166000	80	195	1100	530	320	390	455	M30	24	240	240	181	0	4	360	32	2	250
260	65000	100	240	1000	550	360	430	500	M24	16	105	105	60	0	4	400	22,5	2	130
260 M	100000	75	185	1000	580	360	430	500	M24	24	125	125	83	0	4	400	21	2	183
260 II	130000	100	240	1000	550	360	430	500	M24	24	210	210	132	0	4	400	39	2	262
260 II-M	200000	75	185	1000	580	360	430	500	M30	24	250	250	176	0	4	400	37	2	369
300	78000	90	225	1000	630	410	480	560	M24	24	105	105	60	0	4	460	22,5	3	174
300 M	125000	70	175	1000	630	410	480	560	M24	24	125	125	83	0	4	460	21	3	210
300 II	156000	90	225	1000	630	410	480	560	M24	24	210	210	134	0	4	460	38	3	351

NOTES

- $T_{max} = 2 \times T_{KN}$
» Refer to Selection page 10 to 13
- This maximum allowable torque transmission speed n_{max} must not be exceeded when transmitting torque
- This minimum allowable overrunning speed n_{imin} should not be reduced under continuous operation.
Possible reduction of this minimum speed on request
- Inner race overruns
Keyway to DIN 6885.1
- Tolerance +1

Cover F8 must be ordered separately
» Refer to mounting and maintenance instructions page 16 to 19

Other bore diameters on request

MOUNTING EXAMPLE

