

RIZ RINZ



TYPE



Types RIZ, RINZ are centrifugal lift off sprag type freewheels with the inner race rotating. Suitable for backstop, or overrunning clutch applications. Only the inner race is designed for freewheeling.

These units are part of the Stieber modular system. They are bearing supported using series 60.. bearings, grease lubricated and fitted with ZZ seals. Units are delivered as standard lubricated with grease and ready to

install in either a horizontal or vertical position. Types RIZ, RINZ are designed to be used with G series covers. The following pages give further important information for use of this type unit.

If the unit is to be installed inside a housing where oil lubrication is available, please specify type RIW, RIWN. The F series covers from type GFR, GFRN are then used without shaft seals.

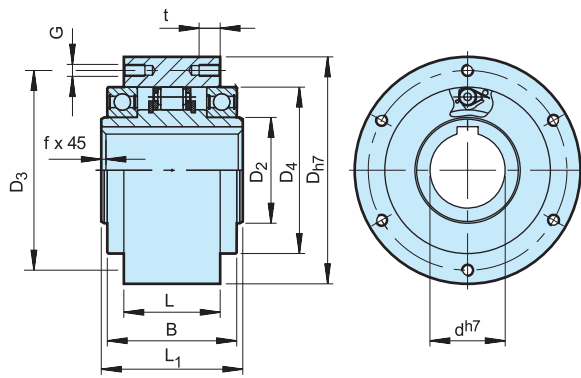

RIZ

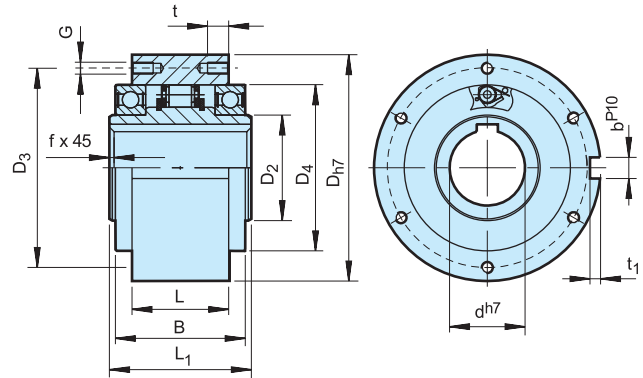

RINZ

Type	Size	Speeds					Number										Weight		
		$T_{KN}^{1)}$ (Nm)	$n_{max}^{2)}$ (min ⁻¹)	$n_{imin}^{3)}$ (min ⁻¹)	$n_{imax}^{4)}$ (min ⁻¹)	D_{h7} (mm)	D_2 (mm)	D_4 (mm)	D_3 (mm)	G	z	L_1 (mm)	L (mm)	B (mm)	t (mm)	f (mm)		t_1 (mm)	b^{P10} (mm)
RIZ RINZ	30	375	290	700	9000	100	45	75	87	M6	6	68	43	60	10	1.0	4	8	2.3
	35	550	280	670	8500	110	50	80	96	M6	6	74	45	63	12	1.0	5	10	3.2
	40	800	260	630	7500	125	55	90	108	M8	6	86	53	73	14	1.5	5	12	4.8
	45	912	255	610	6600	130	60	95	112	M8	8	86	53	73	14	1.5	5.5	14	5.0
	50	1400	235	560	6000	150	70	110	132	M8	8	94	64	86	14	1.5	5.5	14	7.5
	60	2350	210	510	5300	170	80	125	150	M10	10	114	78	105	16	2.0	7	18	12.7
	70	3050	195	470	4100	190	90	140	165	M10	10	134	95	124	16	2.5	7.5	20	14.5
	80	5800	155	375	4000	210	105	160	185	M10	10	144	100	124	16	2.5	9	22	19.0
	90	8700	145	350	3000	230	120	180	206	M12	10	158	115	143	20	3.0	9	25	29.5
	100	16000	140	340	2400	270	140	210	240	M16	10	182	120	153	24	3.0	10	28	42.5
	130	23000	130	320	2400	310	160	240	278	M16	12	212	152	194	24	3.0	11	32	70

NOTES

- 1) $T_{max} = 2 \times T_{KN}$
» Refer to Selection page 10 to 13
 - 2) This maximum allowable torque transmission speed n_{max} must not be exceeded when transmitting torque
 - 3) This minimum allowable overrunning speed n_{imin} should not be reduced under continuous operation. Possible reduction of this minimum speed on request
 - 4) Inner race overruns
Keyway to DIN 6885.1
- » Refer to mounting and maintenance instructions page 16 to 19

MOUNTING EXAMPLE

