

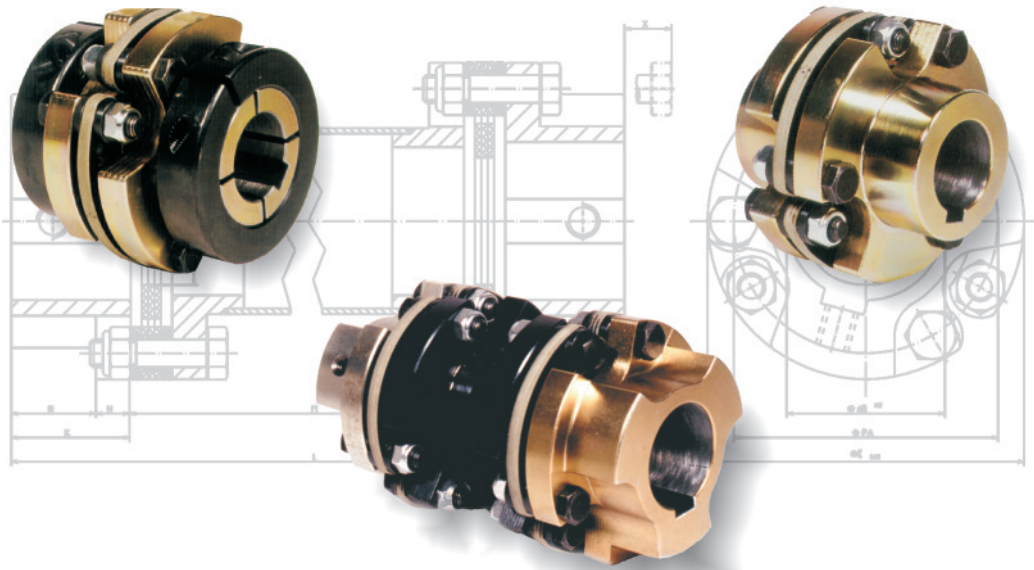

# OMNIFLEX® CD® 2002



C O U P L I N G S



## The Omniflex® CD®

### APPLICATION

The innovative Omniflex® CD® is a unique hybrid coupling, combining the best features found in both steel disc and elastomeric couplings. Through its new open arm disc design and use of rugged composite materials, the coupling offers the high misalignment capacity found in many elastomeric couplings, but with higher torsional stiffness. Compared to steel disc couplings, these couplings offer superior damping and isolation of shock and vibrating loads, including elimination of fretting corrosion and a dramatic reduction of stress fractures at the bolt hole locations. The Omniflex® CD® also provides excellent chemical and moisture resistance in hostile environments that prove difficult or impossible for elastomeric or steel disc couplings.

### TECHNICAL FEATURES and BENEFITS TO THE USER

#### Torsionally Stiff

The Omniflex® CD® offers high torsional stiffness, important for applications such as servomotors, printing presses, packaging machines, line shafts and other equipment requiring registration of machine components. The high torsional stiffness eliminates or minimizes windup problems and generally raises the system resonant frequency.

#### Compact Design

The Omniflex® CD® disc packs consist of discs held together with precision bushings, reducing the number of loose parts to be handled when assembling or disassembling the coupling.

#### Large Misalignment Capacity

Unlike traditional steel disc Single Flex Couplings (which allow no parallel misalignment), the Omniflex® CD® Single Flex coupling allows up to

1mm radial misalignment in a single disc pack, and up to 3° angular misalignment. This capability eliminates the need to specify larger, more expensive Double Flex couplings, saving installation time, space and money. An Omniflex® CD® Double Flex coupling allows up to 3.5mm parallel misalignment and up to 3° angular misalignment. This capability allows for a visual alignment in many applications. The Double Flex model can accommodate the additional misalignment induced by machine base settling, temperature change or bearing wear.

#### Long Life

The composite flex disc material and open arm disc design provide excellent fatigue properties, will not corrode under most operating conditions, reduces movement and eliminates fretting corrosion between discs, a potential problem with steel disc couplings.

#### Easy Installation

Omniflex® CD® hubs are designed to allow the bolts to be withdrawn and the disc packs and/or intermediate members to be removed without disturbing the hubs or connected equipment.

#### Robust

The composite flex disc material is inert to water corrosion. Discs lose less than 10% strength when exposed to 30% sulfuric acid bath and handle most industrial applications within temperature extremes from -57° to +121°C. The hubs, intermediate members and spacers are precision machined from high-grade steel and coated for corrosion protection.

#### Absorbs Vibration

The Omniflex® CD® handles changing loads by damping shock and vibration. The composite flex disc material and unique disc design reduce the transmission of vibration throughout the power train, resulting in less wear and tear on machine components.

#### Maintenance Free

#### Electrically Insulating



# E

### Single Flex

Performance Data Page 6  
Shaft diameters up to 150 mm  
Up to 10.000 Nm



# A

### A-Hub

Single Flex Page 7  
Double Flex Page 10  
Double Flex Spacer Page 13  
Floating Shaft Page 16



# D

### Double Flex

Performance Data Page 9  
Shaft diameters up to 150 mm  
Up to 10.000 Nm



# B

### B-Hub

Single Flex Page 7  
Double Flex Page 10  
Double Flex Spacer Page 13  
Floating Shaft Page 16



# G

### Spacer

Performance Data Page 12  
Shaft diameters up to 150 mm  
Up to 10.000 Nm



# C

### Clamp Hub

Zero backlash hub mounting  
Single Flex Page 8  
Double Flex Page 11  
Double Flex Spacer Page 14  
Floating Shaft Page 17



# F

### Floating Shaft

Performance Data Page 6  
Shaft diameters up to 85 mm  
Up to 2.300 Nm



# S

### S-Hub

Zero backlash hub mounting  
Single Flex Page 8  
Double Flex Page 11  
Double Flex Spacer Page 14  
Floating Shaft Page 17





### Information required

All information refers to operational conditions:

- Service factor (see table)
- Continuous torque:  $T_N$
- Peak torque:  $T_S$
- RPM:  $n_N$
- Axial misalignment:  $\Delta W_a$
- Radial misalignment:  $\Delta W_r$
- Angular misalignment:  $\Delta W_w$
- Shaft diameter
- Space limitation

### Service factors

Load	Service factor
uniform	1,0
light shocks	1,5
medium shocks	2,0
heavy shocks	2,5

### Selection

1. Calculate the design torque:  
 $T_N \times \text{service factor}$
2. Choose a coupling so that:
  - Design torque < continuous rated torque  $T_{KN}$
  - Peak torque:  $T_S < T_{K \max} (= 2 \times T_{KN})$
  - RPM:  $n_N < n_{\max}$
  - Axial misalignment:  $\Delta W_a < \Delta K_a$
  - Radial misalignment:  $\Delta W_r < \Delta K_r$
  - Angular misalignment:  $\Delta W_w < \Delta K_w$
  - $\Delta W_a / \Delta K_a + \Delta W_r / \Delta K_r + \Delta W_w / \Delta K_w < 1$
3. Check to be sure that the coupling fits the required dimensions such as available space envelope and bore sizes.
4. If the coupling size and type meet the torque, misalignment, and space envelope criteria, selection of an Omniflex®CD® is complete.
5. If no Omniflex®CD® coupling is found that meets these criteria, consult the factory. We will work with you to meet your needs.



## LEGEND

$T_{KN}$	Continuous Torque Rating of the Coupling	Nm
$T_{K\ max}$	Maximum Torque Capacity of the Coupling	Nm
$n_{max}$	Maximum Speed of the Coupling	1/min
$\Delta K_r$	Maximum Radial Misalignment Capacity of the Coupling	mm
$\Delta K_a$	Maximum Axial Misalignment Capacity of the Coupling	mm
$\Delta K_w$	Maximum Angular Misalignment Capacity of the Coupling	°
$C_T$	Torsional Stiffness of the Coupling	kNm/rad
$J$	Moment of Inertia of the Coupling	kg cm <sup>2</sup>
$m$	Weight of the Coupling	kg
$T_N$	Continuous Torque	Nm
$T_S$	Peak Torque	Nm
$n_N$	Shaft RPM	1/min
$\Delta W_r$	Maximum Radial Shaft Misalignment	mm
$\Delta W_a$	Maximum Axial Shaft Misalignment	mm
$\Delta W_w$	Maximum Angular Shaft Misalignment	°
$L$	Coupling Length	mm
$\varnothing E$	Coupling Diameter	mm
$\varnothing P$	Hub Diameter	mm
$\varnothing D$	Outer Diameter of Clamping Device	mm
$K$	Total Hub Length	mm
$H$	Disc Thickness	mm
$N$	Hub Length	mm
$\varnothing d$	Bore Diameter	mm
$\varnothing d_{Nut}$	Bore with Keyway Diameter	mm
$\varnothing d_M$	Center-Bore Diameter of the Middle Disc	mm
$X$	Minimum bolt travel to disassemble disc pack	mm
$M$	Distance between Shaft Ends (DBSE)	mm

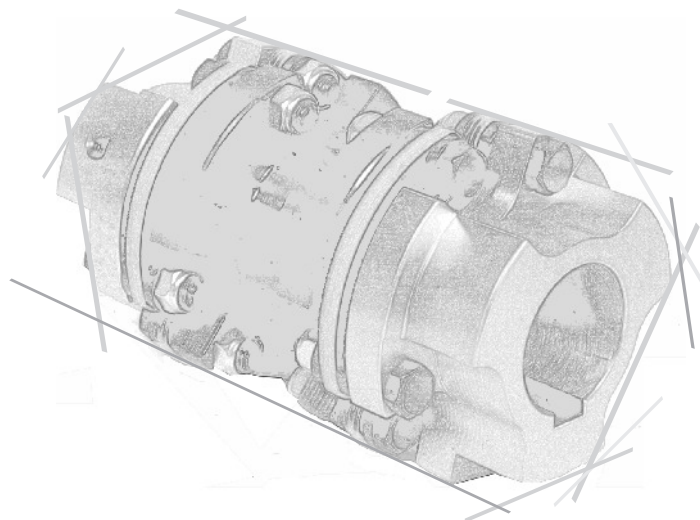

# E

## S I N G L E F L E X P E R F O R M A N C E

- Torsionally Stiff
- Large Misalignment Capacity
- Easy Installation
- Compact Design
- Absorbs Vibration
- Electrically Insulating
- Long Life
- Rugged and Maintenance Free



# E

	T <sub>KN</sub> Nm	n <sub>max</sub> 1/min	ΔK <sub>r</sub> mm	ΔK <sub>a</sub> mm	ΔK <sub>w</sub> °	C <sub>T</sub> kNm/rad	J kg cm <sup>2</sup>	m kg
E18	20	9.000	0,10	0,8	3	12	0,5	0,2
E22	30	8.000	0,15	0,9	3	17	1,4	0,4
E26	55	7.500	0,20	1,1	3	20	2,7	0,6
E30	90	6.500	0,25	1,3	3	43	5,6	0,9
E37	180	5.800	0,30	1,8	3	67	16	1,6
E45	280	5.200	0,35	2,3	3	124	43	2,9
E52	400	4.800	0,45	2,8	3	169	95	4,8
E60	720	4.500	0,50	3,3	3	269	180	6,9
E67	1.165	4.300	0,55	3,8	3	401	325	10
E77	1.765	3.900	0,60	4,1	3	609	610	14
E90	2.825	3.600	0,75	4,6	3	1.040	1.350	23
E105	3.945	3.300	0,85	5,3	3	1.581	3.060	37
E120	5.335	3.000	1,00	6,4	3	2.124	6.010	56

Peak Torque T<sub>K MAX</sub> = 2 × T<sub>KN</sub>



# E

## SINGLE FLEX DIMENSIONS

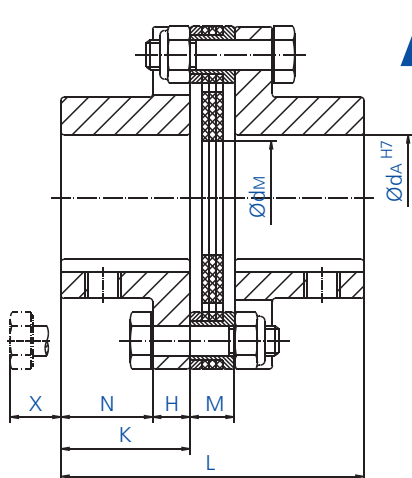

### A

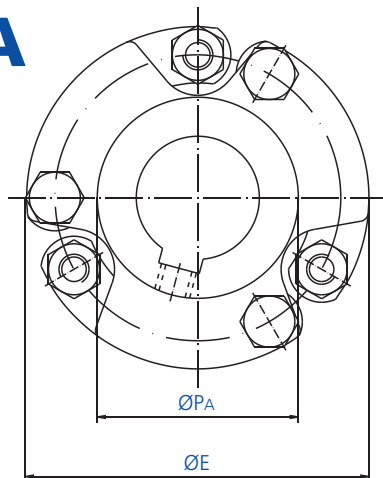

- The Omniflex® CD® is available with standard hubs and keyway: Style A-Hub
- Form-fit version
- Please note the maximum bore:  $\text{Ød}_A$ .

• Both can be freely combined with other Omniflex® CD® hub versions

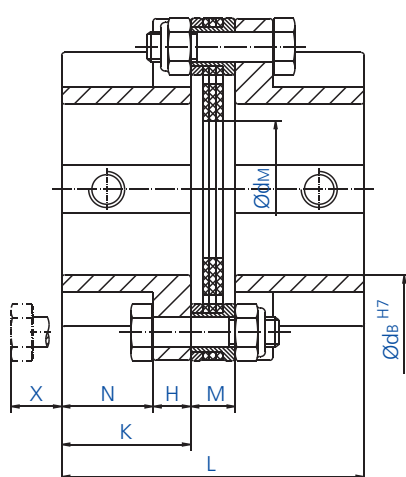

### B

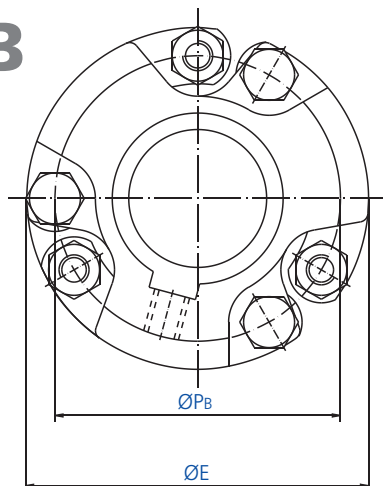

- For large bores, the Omniflex® CD® is available with special hubs and keyway: Style B-Hub
- Form-fit version
- Please note the maximum bore:  $\text{Ød}_B$ .



	L	ØE	ØPA	ØPB	K	H	N	ØdA max	ØdB max	ØdM	X	M
E18	39	47	28	-	16	5,2	10,8	16	-	20	0	7
E22	56	57	30	48	24	7	17	16	26	23	13	8
E26	62	66	38	55	27	8	19	20	32	25	10	8
E30	76	76	42	64	32	8	24	25	35	30	10	12
E37	87	95	55	80	37	12,5	24,5	32	46	38	18	13
E45	101	114	68	95	43	12,5	30,5	41	57	45	24	15
E52	115	133	84	111	49	14,5	34,5	47	66	53	19	17
E60	144	152	93	127	62	16	46	57	76	61	18	20
E67	162	171	108	143	70	16,5	53,5	66	85	69	11	22
E77	186	197	117	164	80	20	60	73	100	79	23	26
E90	219	227	136	191	95	25,5	69,5	76	115	91	36	29
E105	253	267	155	222	108	28,5	79,5	95	130	107	49	37
E120	279	305	186	254	120	30	90	110	152	122	38	39



## E

### S I N G L E F L E X D I M E N S I O N S

- The Omniflex® CD® is available with Clamp Hubs (optional keyway): Style C-Hub
- Press-fit version
- Easy installation
- Please note the maximum bore:  $\varnothing d_c$ .

- Both can be freely combined with other Omniflex® CD® hub versions

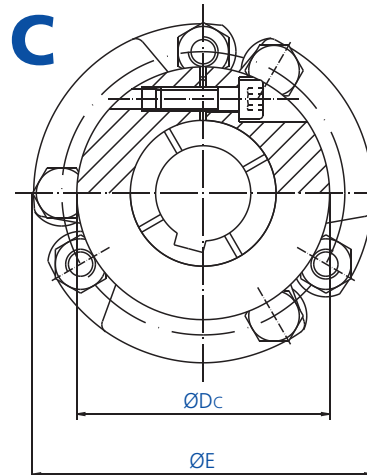
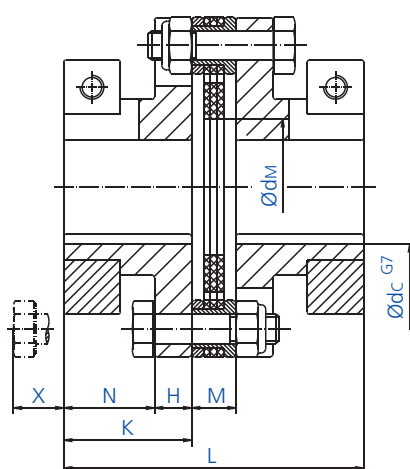

- The Omniflex® CD® is available for Locking Assembly: Style S-Hub
- Press-fit version
- High slip torque
- Please note the maximum bore:  $\varnothing d_s$ .

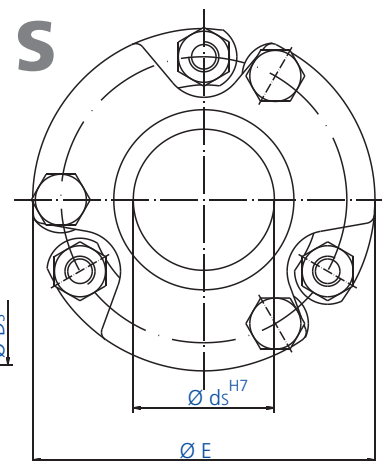
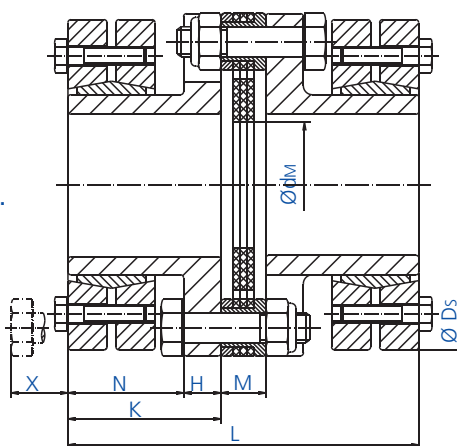

## E

	L	ØE	ØDc	ØDs	K	H	N	Ødc max	Ødc Nut max	Øds max	Ødm	X	M
E18	48	47	45	50	20,5	5,2	15,3	20	16	12	20	0	7
E22	59	57	48	60	25,5	7	18,5	24	16	18	23	13	8
E26	62	66	57	60	27	8	19	32	20	18	25	10	8
E30	76	76	67	72	32	8	24	35	25	26	30	10	12
E37	101	95	83	90	44	12,5	31,5	46	32	42	38	18	13
E45	112	114	89	110	48,5	12,5	36	57	41	60	45	24	15
E52	122	133	108	115	52,5	14,5	38	66	47	70	53	19	17
E60	144	152	121	155	62	16	46	76	57	75	61	18	20
E67	162	171	134	155	70	16,5	53,5	85	66	80	69	11	22
E77	186	197	-	197	80	20	60	-	-	90	79	23	26
E90	219	227	-	230	95	25,5	69,5	-	-	100	91	36	29
E105	253	267	-	263	108	28,5	79,5	-	-	125	107	49	37
E120	279	305	-	300	120	30	90	-	-	145	122	38	39





# D

## DOUBLE FLEX PERFORMANCE



- Torsionally stiff
- Large Misalignment Capacity
- Easy Installation
- Compact Design
- Absorbs Vibration
- Electrically Insulating
- Long Life
- Rugged and Maintenance Free



# D

	T <sub>KN</sub> Nm	n <sub>max</sub> 1/min	ΔK <sub>r</sub> mm	ΔK <sub>a</sub> mm	ΔK <sub>w</sub> °	C <sub>T</sub> kNm/rad	J kg cm <sup>2</sup>	m kg
D18	20	7.500	0,6	1,5	3	6	0,6	0,2
D22	30	7.000	0,7	1,8	3	8	1,9	0,5
D26	55	6.600	0,8	2,2	3	10	3,5	0,8
D30	90	6.000	1,0	2,5	3	21	7,3	1,1
D37	180	5.300	1,2	3,6	3	33	22	2
D45	280	4.800	1,3	4,6	3	60	56	3,6
D52	400	4.500	1,6	5,6	3	82	120	5,8
D60	720	4.100	1,8	6,6	3	131	230	8,3
D67	1.165	3.800	1,9	7,6	3	195	410	12
D77	1.765	3.300	2,3	8,1	3	297	800	18
D90	2.825	2.800	2,6	9,1	3	506	1.700	28
D105	3.945	2.500	3,2	10,7	3	770	3.990	46
D120	5.335	2.100	3,5	12,7	3	1.034	7.600	68

Peak Torque T<sub>K MAX</sub> = 2 × T<sub>KN</sub>



# D

## DOUBLE FLEX DIMENSIONS

- The Omniflex® CD® is available with standard hubs and keyway: Style A-Hub
- Form-fit version
- Please note the maximum bore:  $\varnothing d_A$ .

- Both can be freely combined with other Omniflex® CD® hub versions.

- For large bores, the Omniflex® CD® is available with special hubs and keyway: Style B-Hub
- Form-fit version
- Please note the maximum bore:  $\varnothing d_B$ .

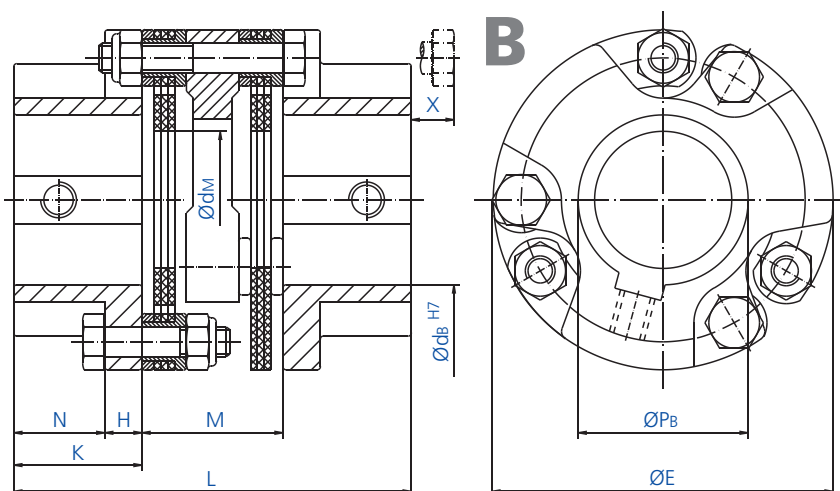
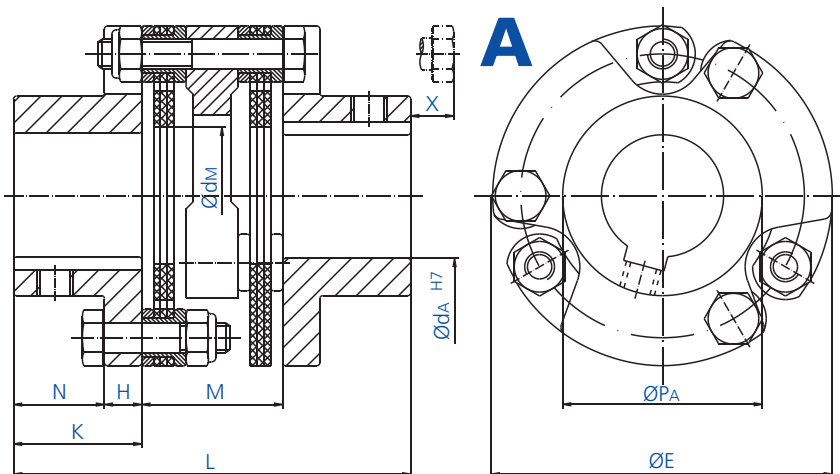

# D

	L	$\varnothing E$	$\varnothing P_A$	$\varnothing P_B$	K	H	N	$\varnothing d_A$ max	$\varnothing d_B$ max	$\varnothing d_M$	X	M
D18	52	47	28	-	16	5,2	10,8	16	-	20	13	20
D22	72	57	30	48	24	7	17	16	26	23	17	24
D26	80	66	38	55	27	8	19	20	32	25	12	26
D30	100	76	42	64	32	8	24	25	35	30	18	36
D37	116	95	55	80	37	12,5	24,5	32	46	38	25	42
D45	133	114	68	95	43	12,5	30,5	41	57	45	35	47
D52	152	133	84	111	49	14,5	34,5	47	66	53	28	54
D60	185	152	93	127	62	16	46	57	76	61	37	61
D67	209	171	108	143	70	16,5	53,5	66	85	69	29	69
D77	240	197	117	164	80	20	60	73	100	79	36	80
D90	281	227	136	191	95	25,5	69,5	76	115	91	38	91
D105	328	267	155	222	108	28,5	79,5	95	130	107	68	112
D120	362	305	186	254	120	30	90	110	152	122	55	122



# D

## DOUBLE FLEX DIMENSIONS

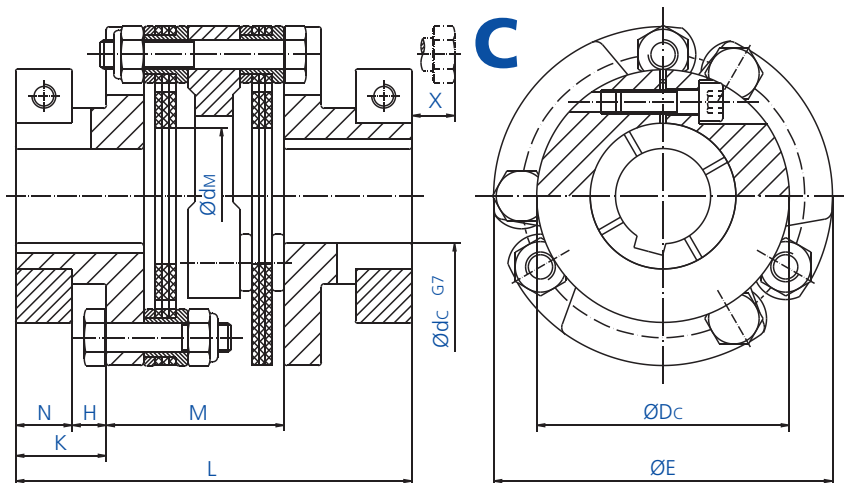

- The Omniflex® CD® is available with Clamp Hubs (optional keyway): Style C-Hub
- Press-fit version
- Easy installation
- Please note the maximum bore:  $\text{Ød}_c$ .
- Both can be freely combined with other Omniflex® CD® hub versions

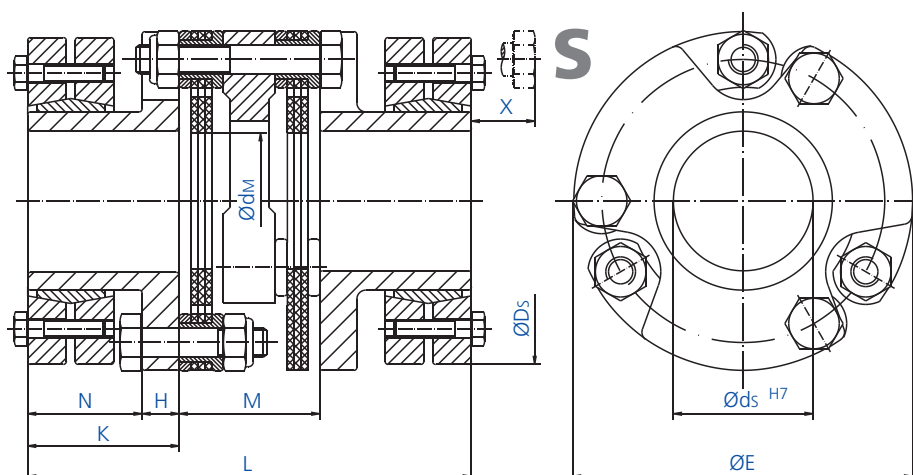

- The Omniflex® CD® is available for Locking Assembly: Style S-Hub
- Press-fit version
- High slip torque
- Please note the maximum bore:  $\text{Ød}_s$ .

# D

	L	ØE	ØDc	ØDs	K	H	N	Ødc max	Ødc Nut max	Øds max	Ødm	X	M
D18	61	47	45	50	20,5	5,2	15,3	20	16	12	20	13	20
D22	75	57	48	60	25,5	7	18,5	24	16	18	23	17	24
D26	80	66	57	60	27	8	19	32	20	18	25	12	26
D30	100	76	67	72	32	8	24	35	25	26	30	18	36
D37	130	95	83	90	44	12,5	31,5	46	32	42	38	25	42
D45	144	114	89	110	48,5	12,5	36	57	41	60	45	35	47
D52	159	133	108	115	52,5	14,5	38	66	47	70	53	28	54
D60	185	152	121	155	62	16	46	76	57	75	61	37	61
D67	209	171	134	155	70	16,5	53,5	85	66	80	69	29	69
D77	240	197	-	197	80	20	60	-	-	90	79	36	80
D90	281	227	-	230	95	25,5	69,5	-	-	100	91	38	91
D105	328	267	-	263	108	28,5	79,5	-	-	125	107	68	112
D120	362	305	-	300	120	30	90	-	-	145	122	55	122



# G

## SPACER PERFORMANCE

- Torsionally stiff
- Large Misalignment
- Capacity
- Easy Installation
- Absorbs Vibration
- Electrically Insulating
- Long Life
- Rugged and Maintenance Free



	T <sub>KN</sub> Nm	n <sub>max</sub> 1/min	ΔK <sub>r</sub> mm	ΔK <sub>a</sub> mm	ΔK <sub>w</sub> °	C <sub>T</sub> kNm/rad	J kg cm <sup>2</sup>	m kg
G18	20	7.000	4	1,5	3	5	1,3	0,5
G22	30	6.500	4	1,8	3	7	2,8	0,7
G26	55	6.000	4	2,2	3	9	5,2	1,1
G30	90	5.400	4	2,5	3	20	9,9	1,5
G37	180	4.700	4	3,6	3	31	31	2,8
G45	280	4.300	4	4,6	3	57	78	4,7
G52	400	4.000	5	5,6	3	78	165	7,3
G60	720	3.600	6	6,6	3	124	322	11
G67	1.165	3.400	6	7,6	3	185	565	15
G77	1.765	2.900	9	8,1	3	281	1090	22
G90	2.825	2.500	10	9,1	3	479	2.480	38
G105	3.945	2.200	10	10,7	3	728	5.410	60
G120	5.335	1.800	12	12,7	3	978	10.300	88

Peak Torque T<sub>K MAX</sub> = 2 × T<sub>KN</sub>



# G

### SPACER DIMENSIONS

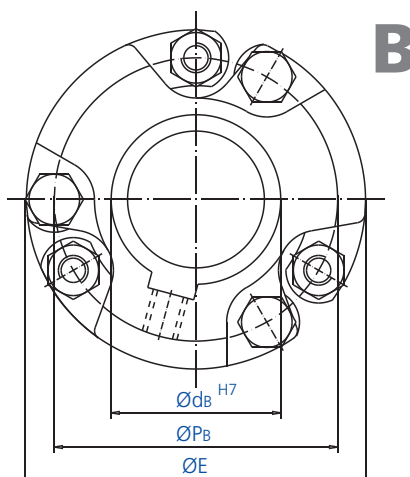
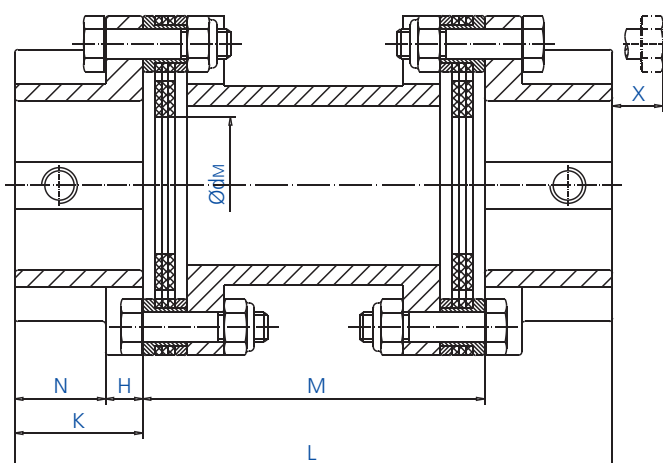
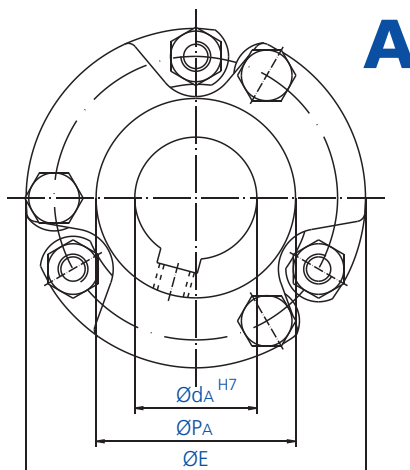
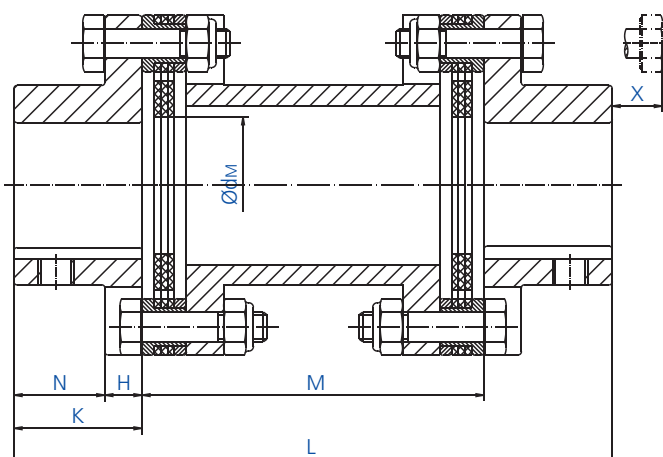

# A

# B

# G

	L	ØE	ØPA	ØPB	K	H	N	ØdA max	ØdB max	ØdM	X	M
G18	121	47	28	-	16	5,2	10,8	16	-	20	0	89
G22	137	57	30	48	24	7	17	16	26	23	13	89
G26	143	66	38	55	27	8	19	20	32	25	10	89
G30	153	76	42	64	32	8	24	25	35	30	10	89
G37	163	95	55	80	37	12,5	24,5	32	46	38	18	89
G45	175	114	68	95	43	12,5	30,5	41	57	45	24	89
G52	209	133	84	111	49	14,5	34,5	47	66	53	19	111
G60	251	152	93	127	62	16	46	57	76	61	18	127
G67	267	171	108	143	70	16,5	53,5	66	85	69	11	127
G77	338	197	117	164	80	20	60	73	100	79	23	178
G90	393	227	136	191	95	25,5	69,5	76	115	91	36	203
G105	419	267	155	222	108	28,5	79,5	95	130	107	49	203
G120	481	305	186	254	120	30	90	110	152	122	38	241



# G

### SPACER DIMENSIONS

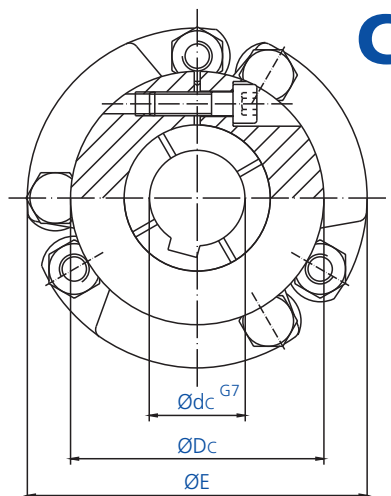
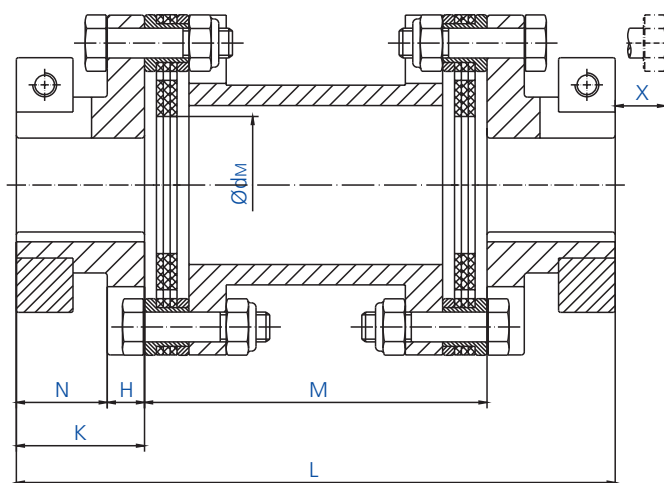

# C

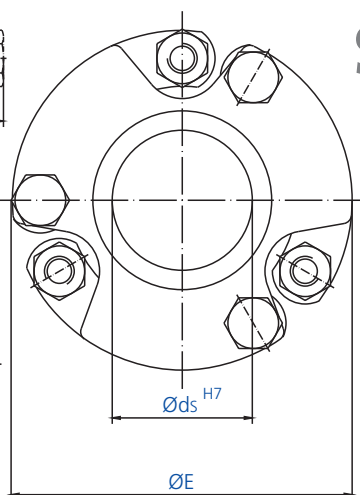
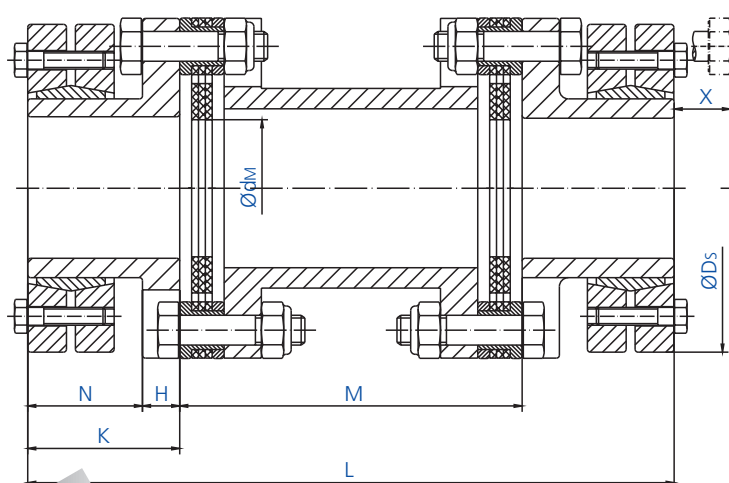

# S

# G

	L	ØE	ØDc	ØDs	K	H	N	Ødc max	Ødc Nut max	Øds max	ØdM	X	M
G18	130	47	45	50	20,5	5,2	15,3	20	16	12	20	0	89
G22	140	57	48	60	25,5	7	18,5	24	16	18	23	13	89
G26	143	66	57	60	27	8	19	32	20	18	25	10	89
G30	153	76	67	72	32	8	24	35	25	26	30	10	89
G37	177	95	83	90	44	12,5	31,5	46	32	42	38	18	89
G45	186	114	89	110	48,5	12,5	36	57	41	60	45	24	89
G52	216	133	108	115	52,5	14,5	38	66	47	70	53	19	111
G60	251	152	121	155	62	16	46	76	57	75	61	18	127
G67	267	171	134	155	70	16,5	53,5	85	66	80	69	11	127
G77	338	197	-	197	80	20	60	-	-	90	79	23	178
G90	393	227	-	230	95	25,5	69,5	-	-	100	91	36	203
G105	419	267	-	263	108	28,5	79,5	-	-	125	107	49	203
G120	481	305	-	300	120	30	90	-	-	145	122	38	241



# F

## FLOATING SHAFT PERFORMANCE

# F

	T <sub>KN</sub> Nm	n <sub>max</sub> 1/min	ΔK <sub>r</sub> mm	ΔK <sub>a</sub> mm	ΔK <sub>w</sub> °	C <sub>T</sub> kNm/rad	Z1	Y1	J kg cm <sup>2</sup>	J Faktor	m kg	m Faktor
F22	30	-	52	1,5	3	3,3	0,33	138	2,5	2,5	0,9	0,97
F26	55	-	52	1,8	3	5,6	0,56	344	5,6	5,6	1,5	1,5
F30	90	-	52	2,5	3	8,1	0,81	344	10	10	1,9	1,5
F37	180	-	52	3,6	3	24	2,4	2.146	35	35	3,8	3,7
F45	280	-	52	4,1	3	47	4,7	4.205	82	82	6	4,5
F52	400	-	52	4,6	3	65	6,5	5.874	179	179	9,5	5,2
F60	720	-	52	5,1	3	103	10,3	8.765	320	320	13	6,0
F67	1.165	-	52	5,6	3	158	15,8	15.454	588	588	18	7,2

Peak torque:  $T_k \text{ max} = 2 \times T_{KN}$

The values given for J, C<sub>T</sub> and m are for a DBSE of 300 mm.

The value given for ΔK<sub>r</sub> is for a DBSE of 1.000 mm.

For a given DBSE, M, the following holds:

- Torsional Stiffness =  $((Z1 \times Y1) / ((M-300) \times Z1 + Y1)) \times 10$
- Moment of Inertia =  $J + ((M-300) \times J_{\text{Factor}})$
- Weight =  $m + ((M-300) \times m_{\text{Factor}})$
- Maximum Radial Misalignment Capacity of the Coupling =  $\Delta k_r \times M$

The Omniflex® CD® is available with:

- Standard hubs and keyway: Style A-Hub
- For large bores, special hubs and keyway: Style B-Hub
- Clamp Hubs (optional keyway): Style C-Hub
- For Locking Assembly: Style S-Hub



- Torsionally stiff
- Large Misalignment Capacity
- Easy Installation
- Absorbs Vibration
- Electrically Insulating
- Long Life
- Rugged and Maintenance Free
- Optional dynamic balancing
- Order example: F45 CØ40N CØ40N, L=1.100

M <sub>max</sub> mm	2.250 1/min	2.000 1/min	1.750 1/min	1.500 1/min	1.250 1/min	1.000 1/min	900 1/min	750 1/min	650 1/min	500 1/min
F22	1.190	1.260	1.350	1.460	1.600	1.780	1.880	2.060	2.210	2.530
F26	1.330	1.410	1.510	1.630	1.780	1.990	2.100	2.300	2.470	2.820
F30	1.330	1.410	1.510	1.630	1.780	1.990	2.100	2.300	2.470	2.820
F37	1.290	1.700	1.910	2.060	2.260	2.530	2.670	2.920	3.140	3.580
F45	1.510	2.010	2.150	2.330	2.550	2.850	3.000	3.290	3.540	4.030
F52	650	980	1.460	2.200	2.680	2.990	3.150	3.460	3.710	4.230
F60	840	1.240	1.820	2.610	2.860	3.200	3.370	3.700	3.970	4.530
F67	820	1.250	1.870	2.840	3.150	3.520	3.710	4.060	4.360	4.980



# F

## FLOATING SHAFT DIMENSIONS

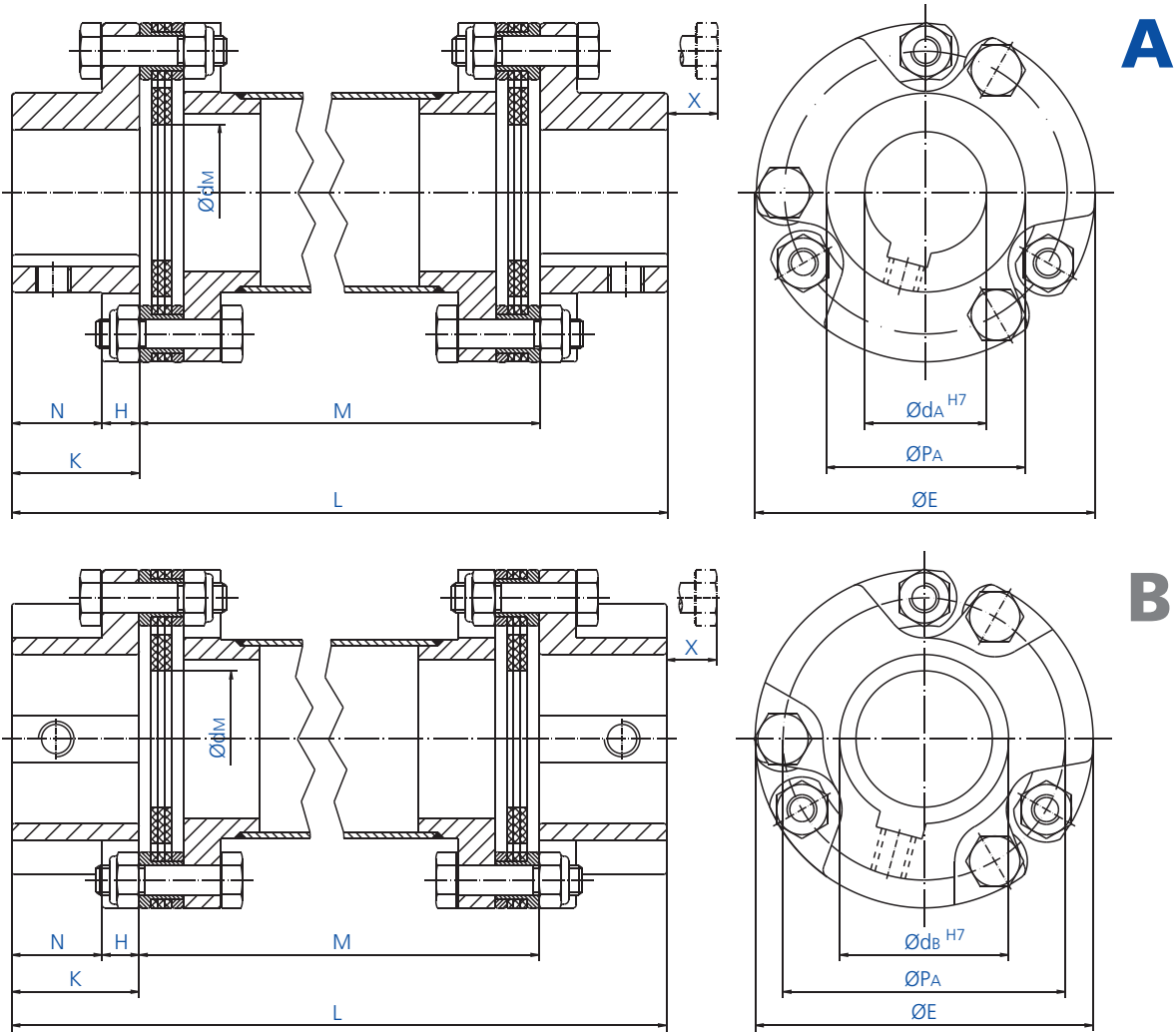

# F

	L	ØE	ØPA	ØPB	K	H	N	ØdA max	ØdB max	ØdM	X	M min
F22	-	57	30	48	24	7	17	16	26	23	13	80
F26	-	66	38	55	27	8	19	20	32	25	10	90
F30	-	76	42	64	32	8	24	25	35	30	10	100
F37	-	95	55	80	37	12,5	24,5	32	46	38	18	140
F45	-	114	68	95	43	12,5	30,5	41	57	45	24	180
F52	-	133	84	111	49	14,5	34,5	47	66	53	19	205
F60	-	152	93	127	62	16	46	57	76	61	18	230
F67	-	171	108	143	70	16,5	53,5	66	85	69	11	265





# F

## FLOATING SHAFT DIMENSIONS

# C

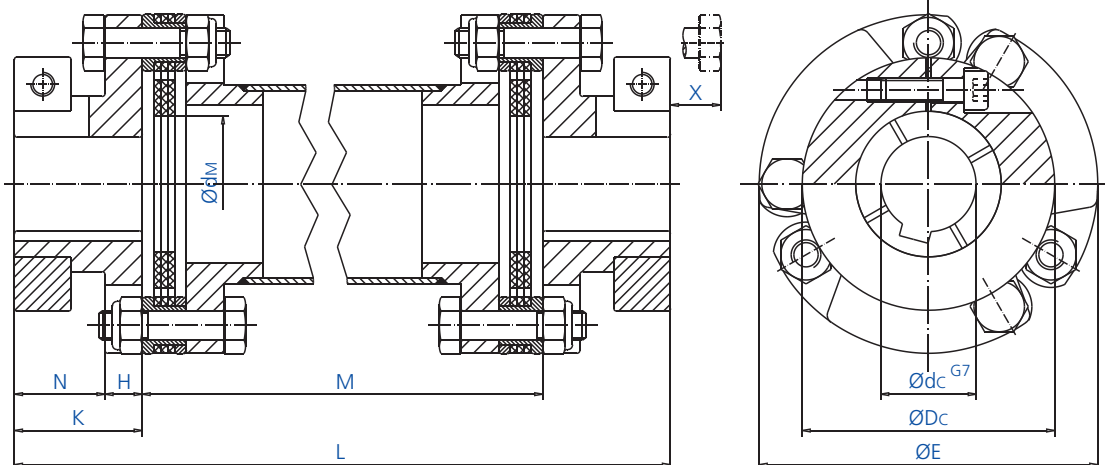

# S

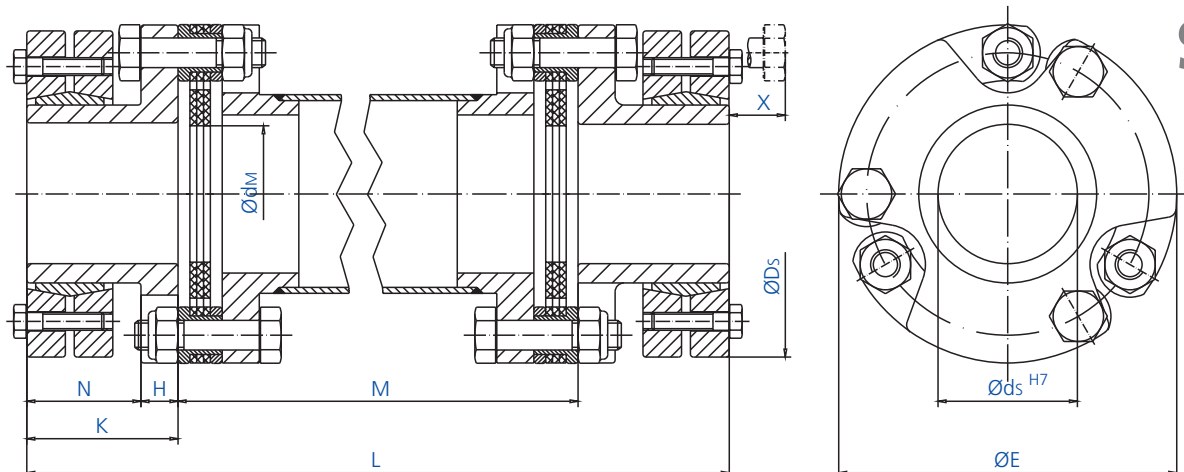

# F

	L	ØE	ØDc	ØDs	K	H	N	Ødc max	Ødc Nut max	Øds max	ØdM	X	M min
F22	-	57	48	60	25,5	7	18,5	24	16	18	23	13	80
F26	-	66	57	60	27	8	19	32	20	18	25	10	90
F30	-	76	67	72	32	8	24	35	25	26	30	10	100
F37	-	95	83	90	44	12,5	31,5	46	32	42	38	18	140
F45	-	114	89	110	48,5	12,5	36	57	41	60	45	24	180
F52	-	133	108	115	52,5	14,5	38	66	47	70	53	19	205
F60	-	152	121	155	62	16	46	76	57	75	61	18	230
F67	-	171	134	155	70	16,5	53,5	85	66	80	69	11	265





### ORDERING PROCEDURE

1. Use the selection procedure to choose an Omniflex® CD® coupling.  
Example: D37
2. Specify bore size and hub design.

### Hub Designs

- A: Standard Hub** with keyway DIN 6885/1.  
Specify bore size. Note the maximum value in the dimension table  $\varnothing d_A$ .  
Example: A $\varnothing$ 40N
- B: Special Hub** with keyway DIN 6885/1.  
Specify bore size. Note the maximum value in the dimension table  $\varnothing d_B$ .  
Example: B $\varnothing$ 40N
- C: Clamp Hub** (optional keyway DIN 6885/1).  
Specify bore size. Note the maximum value in the dimension table  $\varnothing d_C$ .  
Examples: C $\varnothing$ 20, C $\varnothing$ 20N
- S: for Locking Assembly.** Specify bore size. Note the maximum value in the dimension table  $\varnothing d_S$ .  
Example: S $\varnothing$ 32

### Examples

- E37 A $\varnothing$ 25N A $\varnothing$ 32N
- D37 C $\varnothing$ 25 C $\varnothing$ 30N
- D45 A $\varnothing$ 40N B $\varnothing$ 45N

### Service factors

Load	Service factor
uniform	1,0
light shocks	1,5
medium shocks	2,0
heavy shocks	2,5

### General

If the standard Omniflex® CD® couplings listed in the catalog do not meet your requirements, consult the factory. We will work with you to meet your needs.

Many factors influence the operating life of a coupling. The influence of torque, RPM and misalignment are discussed in the following.

### Torque

The maximum torque  $T_{K\max}$  ( $= 2 \times T_{KN}$ ) should not be exceeded.

The design torque is calculated as follows:

$$T_N \times \text{Service factor}$$

The torque carrying capacity of the Omniflex® CD® decreases as radial misalignment and speed increase. For complex applications consult the factory.

### RPM

Due to the design of the Omniflex® CD®, higher speeds lead to higher stress on the coupling. The maximum speed should not be exceeded.

The close tolerances used to manufacture Omniflex® CD® couplings in conjunction with the composite disc pack, make the Omniflex® CD® especially well suited to high speed and long span applications. Occasionally, the application may require Dynamic Balancing of the coupling. For complex applications consult the factory.

### Misalignment

- The radial misalignment capacity of the Omniflex® CD®  $\Delta K_r$  should not be exceeded under normal conditions.
- The axial misalignment capacity of the Omniflex® CD®  $\Delta K_a$  should not be exceeded under normal conditions.
- The angular misalignment capacity of the Omniflex® CD®  $\Delta k_w$  should not be exceeded under normal conditions.



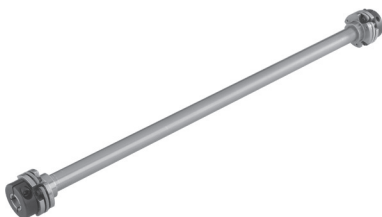

### Copyright

The copyright, trademarks, patents, drawings and other information in this catalog are property of Schmidt-Kupplung GmbH. No part may be reproduced without the prior written consent of Schmidt-Kupplung GmbH.

### Caution

Failure, improper selection, or improper use of these products can cause malfunctions in connected equipment. Malfunctions in connected equipment can cause failure in these products.

Information in this catalog provides product options for further investigation by users having technical expertise. The user must analyze all aspects of the application and review the information regarding the product in the current product catalog. Due to the variety of applications for these products and the diversity of operating conditions that may prevail, the user, through its own analysis and testing, is solely responsible for making the final selection of these products and assuring that all performance, safety and warning requirements relevant to the application are met.

The specifications, availability and pricing of products described in this catalog are subject to change without notice.



## CONTROLFLEX®

The ideal coupling  
for shaft encoders



## SEMIFLEX®

Compact design with high  
misalignment capacity and  
high torsional stiffness

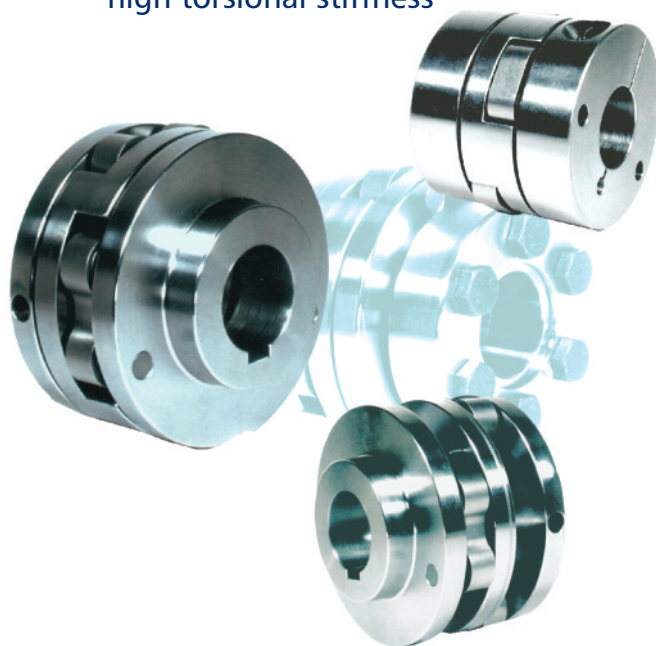

## SCHMIDT-KUPPLUNG®

Our classic for extreme  
shaft-to-shaft offsets



Am Rehmanger 9  
38304 Wolfenbüttel  
Germany  
Fon +49 5331 9552-500  
Fax +49 5331 9552-552  
[www.schmidt-kupplung.de](http://www.schmidt-kupplung.de)  
[info@schmidt-kupplung.de](mailto:info@schmidt-kupplung.de)