



The Semiflex® series



Standard F series

Symbiosis of performance and compact design

Bore diameter up to 120 mm
Torque (T_{KN}) 44 Nm to 7.040 Nm



Compact Plus C series

For extremely axially limited space

Bore diameter up to 100 mm
Torque (T_{KN}) 69 Nm to 7.040 Nm



Dynamic D series

The light-weight aluminum series

Bore diameter up to 35 mm
Torque (T_{KN}) 40 Nm to 180 Nm

Semiflex®

Semiflex® is a high-precision coupling in a compact design and with no restoring forces. Semiflex® offers large radial misalignment capacity in a very small envelope. Semiflex® is, by design, free of restoring forces. For highly dynamic applications, Semiflex® is also available in an aluminum series.

Compact Plus C series

Compact Plus: for extremely axially limited space. It offers up to 25% shorter length in comparison with the Standard series and no reduction in performance or misalignment capacity.

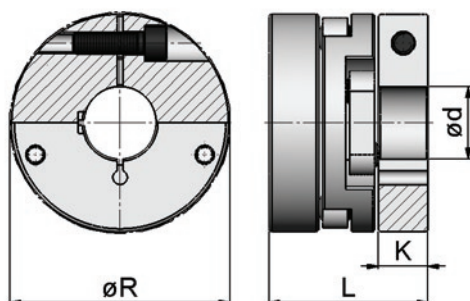

Hub version 1: clamp hub

	T_{KN} (Nm)	TK_{max} (Nm)	n_{max} (1/min)	ΔK_i (mm)	ΔK_a (mm)	ΔK_{st} (°)	C_T (kNm/rad)	J (kg cm ²)	m (kg)	$\varnothing R$ (mm)	L (mm)	K (mm)	$\varnothing d_{max}$ (mm)
C 70	69	112	3.400	1	1	1	13	8,9	1,1	72	59	20	35
C 230	230	460	2.300	1,6	1	1	53	36,8	3	94	88	27,5	44
C 265	265	530	2.200	1,6	1	1	61	54,2	3,4	104	88	27,5	50
C 320	316	635	2.000	3	1	1	73	104,8	4,2	124	88	27,5	70
C 575	575	1.220	1.700	2,4	1	1	140	155	6,9	120	120,5	38	60

Order Example 1: C 70.11 Ø25 Ø25 Order Example 2: C 320.11 Ø38 Ø40

C 320	11	Ø38 Ø40
Type Semiflex® Compact Plus C 320	both sides clamp hub	bore diameters

To ensure the correct selection of the Semiflex® please use the TD Calculator of the column Semiflex® or please use our selection procedure and legend area to download the required information.

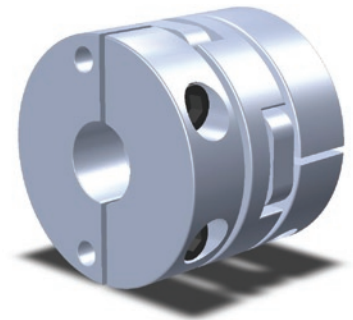
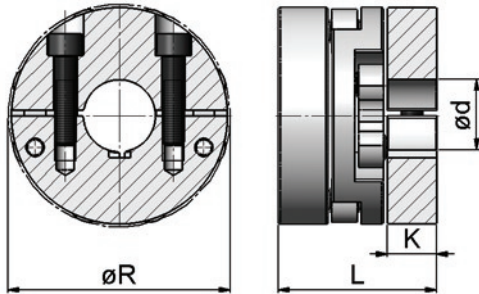

Hub version 2: split-clamp hub

	T_{KN} (Nm)	T_{Kmax} (Nm)	n_{max} (1/min)	ΔK_1 (mm)	ΔK_2 (mm)	ΔK_w (°)	C_1 (kNm/rad)	J (kg cm ²)	m (kg)	ØR (mm)	L (mm)	K (mm)	Ød _{max} (mm)
C 70	69	112	3.400	1	1	1	13	8,9	1,1	72	59	20	25
C 230	230	460	2.300	1,6	1	1	53	36,8	3	94	88	27,5	30
C 265	265	530	2.200	1,6	1	1	61	54,2	3,4	104	88	27,5	35
C 320	316	635	2.000	3	1	1	73	104,8	4,2	124	88	27,5	45
C 575	575	1.220	1.700	2,4	1	1	140	155	6,9	120	120,5	38	35

Order Example 1: C 70.22 Ø20 Ø20

Order Example 2: C 320.22 Ø38 Ø40

C 320	22	Ø38 Ø40
Type Semiflex® Compact Plus C 320	both sides split-clamp hub	bore diameters

To ensure the correct selection of the Semiflex® please use the TD Calculator of the column Semiflex® or please use our selection procedure and legend area to download the required information.

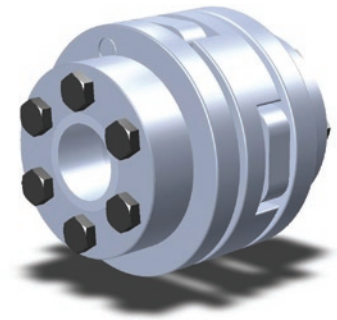
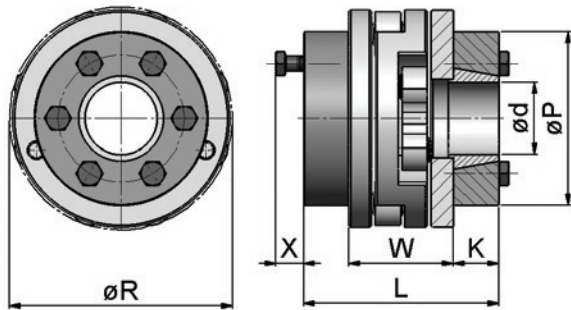

Hub version 3: locking-assembly

	T_{KN} (Nm)	$T_{K,max}$ (Nm)	n_{max} (1/min)	ΔK_r (mm)	ΔK_a (mm)	ΔK_w (°)	C_T (kNm/rad)	J (kg cm ²)	m (kg)	$\varnothing R$ (mm)	L (mm)	X (mm)	W (mm)	K (mm)	$\varnothing P$ (mm)	standard bore diameters (mm)
C 230	230	460	2.300	1,6	1	1	53	34,3	3,2	94	100	15	58	21	76	25, 28, 30
C 265	265	530	2.200	1,6	1	1	61	41,2	3,4	104	100	15	58	21	66	25, 28, 30
C 320	316	635	2.000	3	1	1	73	81,5	4,6	124	100	15	58	21	76	25, 28, 30
C 575	575	1.220	1.700	2,4	1	1	140	134	7,2	120	128,5	17	78,5	25	96	30, 32, 35, 40
C 725	725	1.530	1.600	2,4	1	1	175	270	10,5	140	138,5	23	78,5	30	115	42, 45, 50
C 830	828	1.755	1.500	4	1	1	201	381	12	160	138,5	23	78,5	30	115	42, 45, 50
C 1370	1.370	3.340	1.300	3	1	0,8	383	530	16	163	170	23	110	30	115	42, 45, 50
C 1580	1.580	3.845	1.200	4	1	0,8	441	835	19,5	183	178	24	110	34	120	50, 55, 60
C 2390	2.390	5.855	1.100	3,2	1	0,7	671	1.195	27	183	207	30	127	40	155	60, 65, 70
C 2700	2.700	6.600	1.000	4,4	1	0,5	756	1.600	30,5	203	207	30	127	40	155	60, 65, 70
C 5620	5.620	15.050	900	5,4	2	0,3	1.725	4.250	51,5	250	240	31	152	44	170	70, 75, 80
C 7040	7.040	18.840	800	6,6	2	0,3	2.159	8.900	75,5	300	252	30	152	50	185	80, 85, 90

Order Example 1: C 70.33 Ø20 Ø25 Order Example 2: C 320.33 Ø30 Ø30

C 320	33	Ø30 Ø30
Type Semiflex® Compact Plus C 320	both sides locking-assembly	bore diameters

To ensure the correct selection of the Semiflex® please use the TD Calculator of the column Semiflex® or please use our selection procedure and legend area to download the required information.

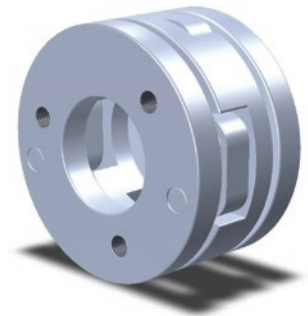
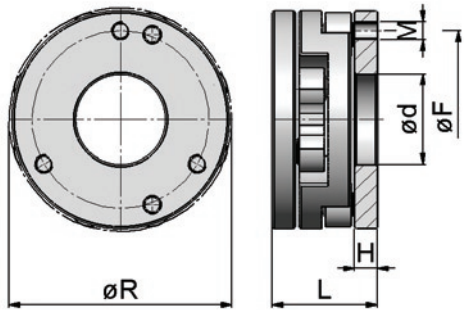

Hub version 5: flange-mounting

	$T_{K_{\text{N}}}$ (Nm)	$T_{K_{\text{max}}}$ (Nm)	n_{max} (1/min)	ΔK_t (mm)	ΔK_a (mm)	ΔK_w (°)	C_T (kNm/rad)	J (kg cm ²)	m (kg)	$\varnothing R$ (mm)	L (mm)	H (mm)	$\varnothing F$ (mm)	M
C 70	69	112	3.400	1	1	1	13	5	0,7	72	35	8	56	3xM6
C 230	230	460	2.300	1,6	1	1	53	22	1,8	94	58	12,5	70	3xM10
C 265	265	530	2.200	1,6	1	1	61	34	2,2	104	58	12,5	70	3xM10
C 320	316	635	2.000	3	1	1	73	68	3,1	124	58	12,5	98	3xM10
C 575	575	1.220	1.700	2,4	1	1	140	99	4,8	120	78,5	17	90	3xM16
C 725	725	1.530	1.600	2,4	1	1	175	187	6,5	140	78,5	17	110	3xM16
C 830	828	1.755	1.500	4	1	1	201	292	7,6	160	78,5	17	120	3xM16
C 1370	1.370	3.340	1.300	3	1	0,8	383	434	12	163	110	26	120	3xM20
C 1580	1.580	3.845	1.200	4	1	0,8	441	703	15	183	110	26	140	3xM20
C 2390	2.390	5.855	1.100	3,2	1	0,7	671	851	18	183	127	31	135	5xM20
C 2700	2.700	6.600	1.000	4,4	1	0,5	756	1.299	22	203	127	31	150	5xM20
C 5620	5.620	15.050	900	5,4	2	0,3	1.725	3.499	37	250	152	33	200	5xM24
C 7040	7.040	18.840	800	6,6	2	0,3	2.159	7.064	47	300	152	33	250	5xM24

Order Example 1: C 70.55 Order Example 2: C 575.55

C 575	55
Type Semiflex® Compact Plus C 575	both sides flange-mounting

To ensure the correct selection of the Semiflex® please use the TD Calculator of the column Semiflex® or please use our selection procedure and legend area to download the required information.

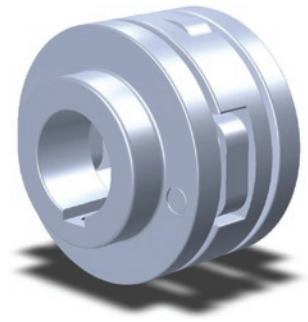
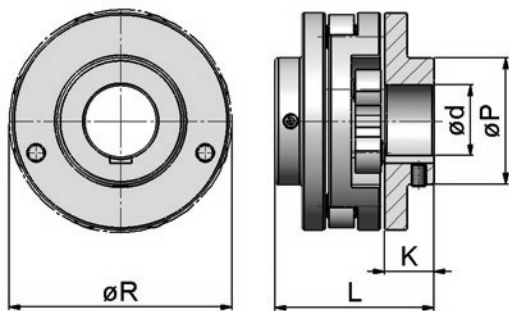

Hub version 6: standard hub

	T_{KN} (Nm)	T_{Kmax} (Nm)	n_{max} (1/min)	ΔK_r (mm)	ΔK_a (mm)	ΔK_w (°)	C_r (kNm/rad)	J (kg cm ²)	m (kg)	ØR (mm)	L (mm)	Ød _{max} (mm)	ØP (mm)	K (mm)
C 70	69	112	3.400	1	1	1	13	8,9	1,1	72	59	40	70	20
C 230	230	460	2.300	1,6	1	1	53	25,4	2,3	94	88	40	56	27,5
C 265	265	530	2.200	1,6	1	1	61	37,2	2,6	104	88	50	65	27,5
C 320	316	635	2.000	3	1	1	73	73,9	3,5	124	88	50	70	27,5
C 575	575	1.220	1.700	2,4	1	1	140	108	6,6	120	120,5	45	70	38
C 725	725	1.530	1.600	2,4	1	1	175	205	7,7	140	126,5	55	85	41
C 830	828	1.755	1.500	4	1	1	201	324	9,5	160	140,5	60	90	48
C 1370	1.370	3.340	1.300	3	1	0,8	383	460	13	163	146	60	90	44
C 1580	1.580	3.845	1.200	4	1	0,8	441	755	17	183	158	60	90	50
C 2390	2.390	5.855	1.100	3,2	1	0,7	671	910	20	183	167	60	90	51
C 2700	2.700	6.600	1.000	4,4	1	0,5	756	1.340	24	203	177	65	95	56
C 5620	5.620	15.050	900	5,4	2	0,3	1.725	3.800	43,5	250	222	80	120	68
C 7040	7.040	18.840	800	6,6	2	0,3	2.159	8.550	71,5	300	278	100	160	96

Order Example 1: C 70.66 Ø25 Ø25 Order Example 2: C 320.66 Ø38 Ø40

C 320	66	Ø38 Ø40
Type Semiflex® Compact Plus C 320	both sides standard hub	bore diameters

To ensure the correct selection of the Semiflex® please use the TD Calculator of the column Semiflex® or please use our selection procedure and legend area to download the required information.

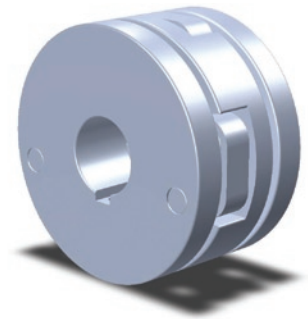
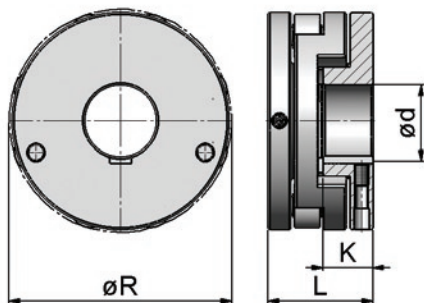

Hub version 7: internal hub

	T_{ken} (Nm)	$T_{\text{k,max}}$ (Nm)	n_{max} (1/min)	ΔK_r (mm)	ΔK_a (mm)	ΔK_{vr} (°)	C_t (kNm/rad)	J (kg cm ²)	m (kg)	ØR (mm)	L (mm)	K (mm)	Ød_{max} (mm)
C 230	230	460	2.300	1,6	1	1	53	24,3	2,2	94	58	27,5	25
C 265	265	530	2.200	1,6	1	1	61	36,6	2,7	104	58	27,5	35
C 320	316	635	2.000	3	1	1	73	72,9	3,5	124	58	27,5	45
C 575	575	1.220	1.700	2,4	1	1	140	104	5,4	120	78,5	38	30
C 1370	1.370	3.340	1.300	3	1	0,8	383	455	13,5	163	110	44	40
C 1580	1.580	3.845	1.200	4	1	0,8	441	745	16,5	183	110	50	60
C 2700	2.700	6.600	1.000	4,4	1	0,5	756	1.330	23,5	203	127	56	70
C 5620	5.620	15.050	900	5,4	2	0,3	1.725	3.775	42	250	152	68	90

Order Example 1: C 265.77 Ø25 Ø25 Order Example 2: C 725.77 Ø35 Ø35

C 725	77	Ø35 Ø35
Type Semiflex® Compact Plus C 725	both sides internal hub	bore diameters

To ensure the correct selection of the Semiflex® please use the TD Calculator of the column Semiflex® or please use our selection procedure and legend area to download the required information.

1. Calculation of the design torque. Please multiply your continuous torque by the required performance factor (table 1) and the required service factor (table 2) to get the design torque.

An alternative:

simply use under www.schmidt-kupplung.com the

TD Calculator of the column Semiflex®

5. Make sure that the misalignment capability is sufficient. There is a trade-off between the radial, axial and angular misalignment capabilities. Be certain that the combined percentages of each do not exceed 100%.

Table 1: performance factor

speed range 1/min	service life (h)	performance factor
0-500	5.000	1,8
0-500	10.000	2,3
0-500	20.000	2,8
500-1.000	5.000	2,3
500-1.000	10.000	2,8
500-1.000	20.000	3,5
1.000-2.000	5.000	2,8
1.000-2.000	10.000	3,6
1.000-2.000	20.000	4,4
2.000-3.000	5.000	3,2
2.000-3.000	10.000	4
2.000-3.000	20.000	4,8

Table 2: service factor

uniform	1
light shocks	1,5
medium shocks	2
heavy shocks	2,5

2. Select a coupling size that has a continuous torque rating greater than your calculated design torque.
3. Make sure that the peak torque of the application does not exceed the maximum torque rating of the coupling.
4. Please check the coupling maximum speed to be sure it is within the rated maximum speed.

Legend

Performance

T_{KN}	continuous torque rating of the coupling (Nm)
$T_{K\ max}$	maximum torque capacity of the coupling (Nm)
$n_{\ max}$	maximum speed of the coupling (1/min)
ΔK_r	maximum radial misalignment capacity (mm)
ΔK_a	maximum axial misalignment capacity (mm)
ΔK_w	maximum angular misalignment capacity (°)
C_T	torsional stiffness (kNm/rad)
J	moment of inertia (kg cm ²)
m	weight of the coupling (kg)

Dimension

$\varnothing R$	swing diameter (mm)
H	disc thickness (mm)
L	coupling length (mm)
$\varnothing P$	hub diameter (mm)
K	total hub length (mm)
X	mounting space (mm)
W	coupling basis (mm)
$\varnothing F$	bolt circle diameter (mm)
M	number of threaded bores x bolt size
$\varnothing d$	bore diameter (mm)